



Jackson Plant:
308 Alabama Blvd.
Jackson, GA 30233
(800)884-4484/Fax: (800)765-4484

Idabel Plant:
Rt. 3
Idabel, OK 74745
(800)926-8509/Fax: (800)289-6007

Headquarters: Lancaster Plant:
3449 Hempland Road
Lancaster, PA 17601
(800)477-2741/Fax: (800)283-4289

Other Manufacturing Facilities:
Gridley Plant:
Rt. 24 West
Gridley, IL 61744
(800)451-3974/Fax: (800)289-3383

Marshfield Plant:
1820 East 26th Street
Marshfield, WI 76063
(800)528-0878/Fax: (715)387-2424

Tifton Plant:
Highway 41 South & 55 Lamb Loop
Tifton, GA 31793
(800)339-8311/Fax: (800)380-4784

Cedar City Plant:
2402 Industry Way
Cedar City, UT 84720
(800)432-2725/Fax: (800)632-2725

Rathdrum Plant:
6442 Boekel Road
Rathdrum, ID 83858
(888)470-0013/ Fax: (888)632-2725

FABRAL, Inc



5V Crimp

**METAL ROOFING
SYSTEM
ORDERING &
INSTALLATION
SELF HELP
GUIDE**

FABRAL, Inc

5V CRIMP INSTALLATION GUIDELINES

Caution: 5V CRIMP roofing must be applied on a minimum roof pitch of 2½:12 or greater.

Important Notice: This guide must be read and understood in its entirety before beginning installation.

This guide is supplied by FABRAL, Inc. for use by its customers. This is intended to be a guide only, and does not replace or supercede local or state building codes.

FABRAL, Inc. assumes no responsibility for any problems which might arise as a result of improper installation or any personal injury or property damage that might occur with the products use.

Note: *Panels may show slight waviness commonly referred to as “oil canning.” This is a characteristic of roll forming, and will not be accepted as cause for rejection.*

5V CRIMP is designed to be used over solid decking, typically 5/8” minimum thickness plywood.

CHIMNEY FLASHING (DOWNHILL SIDE)

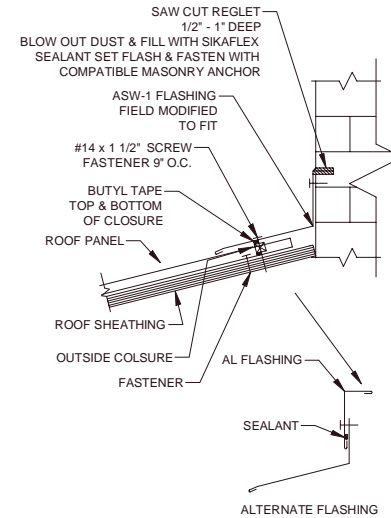

CHIMNEY (ALTERNATE SIDE)

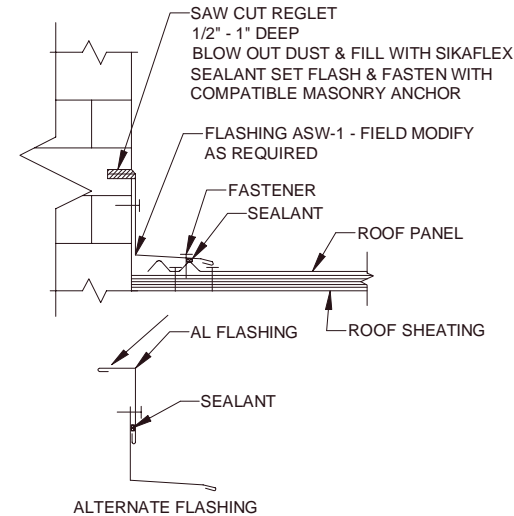

CHIMNEY FLASHING (SIDE)

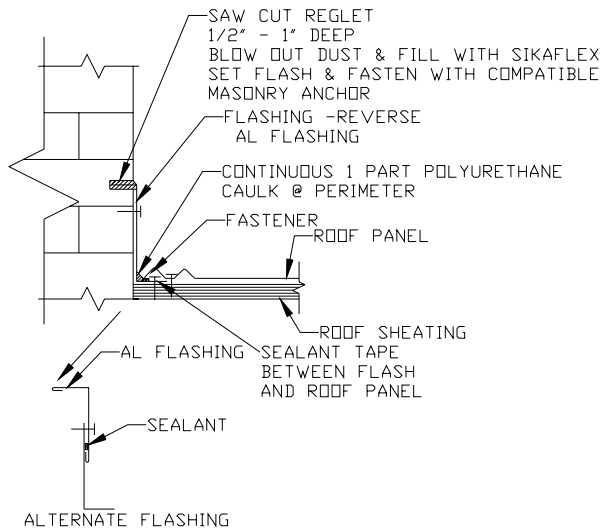

CHIMNEY FLASHING (UPHILL SIDE)

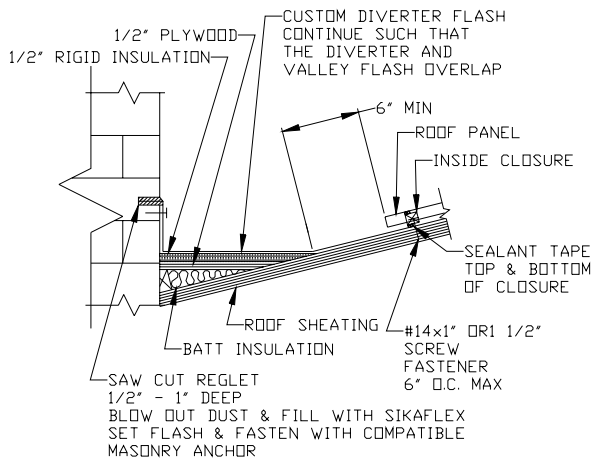

FABRAL, Inc

MINIMUM RECOMMENDED TOOLS & EQUIPMENT

Screw Gun—2,000 to 2,500 rpm Clutch type screw gun with a depth sensing nose piece is recommended to insure proper installation of the screws. The following bits will be required:

- ◆ 1/4" hex
- ◆ 5/16" hex

Snips—For miscellaneous panel and flashing cutting requirements. Three pairs will be required: one for left edge, one for right edge, and one for centerline cuts.

Electric Nibblers or Metal Shears—Used for general metal cutting, such as cutting the panels in hip and valley areas.

Note: Some installers prefer using a circular saw with a metal cutting abrasive blade. This method may be faster, but it has some drawbacks:

1. Saw cut edges are jagged and unsightly and tend to rust more quickly than sheared edges.
2. Saw cutting produces hot metal filings that can embed in the paint and cause rust marks on the face of the panel.
3. Saw cutting burns the paint & galvanizing at the cut edge leading to the onset of edge rust.

Chalk Line—Used to assist in the alignment of panels, flashings, etc.

FABRAL, Inc

MINIMUM RECOMMENDED TOOLS & EQUIPMENT

Caulking Gun—Used for miscellaneous caulking and sealing to inhibit water infiltration.

Marking Tools— (Always make marks on tape rather than directly on the panel.) Indelible markers, pens, or pencils.

Utility Knife—Used for miscellaneous cutting.

Electric Drill—Used to drill pilot holes such as those required for ridge cap installation.

String Line—Use for general alignment and measuring.

Tape Measure—25 foot minimum (another at 50 foot is handy).

Locking Pliers—Standard and “Duckbill” style for miscellaneous clamping and bending of parts.

CHIMNEY FLASHING

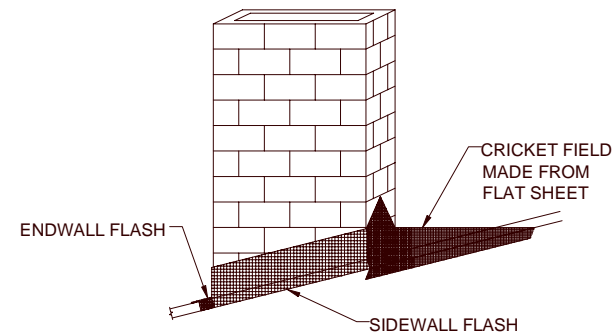

Notes:

1. Procedures for the installation of Chimney Flashings are similar to the Skylights (refer to pages 47-52).
2. The saw-cut reglet shown on pages 52-53 provides the best weather tight installation for chimneys. Fill the reglet with one part polyurethane sealant, insert trim and fasten as necessary with masonry anchors. Heads of masonry anchors can be color-matched with touch-up paint after installation.
3. Flashings may be field-formed from 27 ⁹/₁₆" x 10' flat sheets.

**SKYLIGHT TOP FLASH-
SUGGESTED SHAPE**

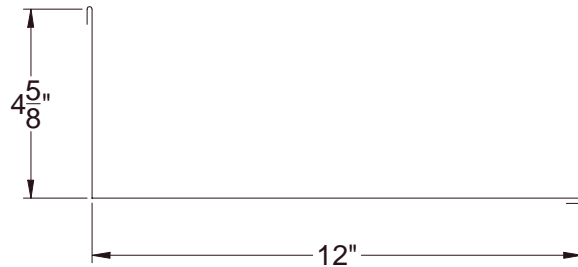

**SKYLIGHT BOTTOM FLASH-
SUGGESTED SHAPE**

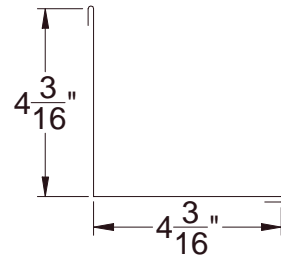

SKYLIGHT DOWNHILL

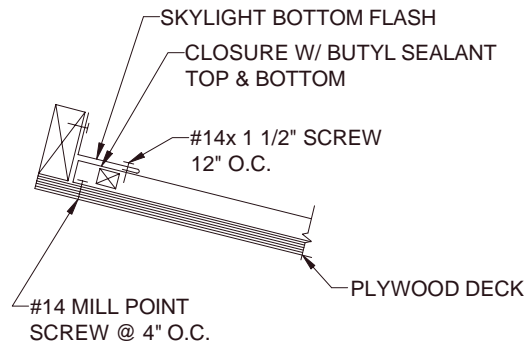

FABRAL, Inc

**SAFETY
CONSIDERATIONS**

- ◆ **Never use unsecured or partially installed panels as a working platform.** Do not walk on panels until they are in place on the roof and all of the fasteners have been installed.
- ◆ **Metal roofing panels are slippery when wet, dusty, frosty, or oily.** Do not attempt to walk on a metal roof under these conditions. Wear soft-soled shoes to improve traction and minimize damage to the paint finish.
- ◆ **Always be aware of your position on the roof relative to your surroundings.** Take note of the locations of roof openings, roof edges, equipment, co-workers, etc.
- ◆ **Always wear proper clothing and safety attire.** Wear proper clothing when working with sheet metal in order to minimize the potential for cuts, abrasions and other injuries. Eye protection and gloves are a must when working with sheet metal products. Hearing protection should be used when power-cutting metal panels.
- ◆ **Use care when operating electrical and other power equipment.** Observe all manufacturer's safety recommendations.
- ◆ **Roof installation on windy days can be dangerous.** Avoid working with sheet metal products on windy days.

FABRAL, Inc

DELIVERY, HANDLING & STORAGE

- ◆ Always inspect the shipment upon delivery. Inspect for damage and verify material quantities against the shipping list. Note any damaged material or shortages at the time of delivery.
- ◆ Handle panel bundles and individual panels with care to avoid damage. Longer bundles and panels may require two or more “pick points” properly spaced to avoid damage that can result from buckling and/or bending of the panels.
- ◆ Store the panels and other materials in a dry, well ventilated area, away from traffic. Elevate one end of the bundle so that any moisture that may have accumulated during shipping can run off. Be sure that air will be able to circulate freely around the bundles to avoid the build-up of moisture. Never store materials in direct contact with the ground.
- ◆ Wear clean, non-marking, soft soled shoes when walking on the panels to avoid shoe marks or damage to the finish. Step only in the flat area of the panels.

SKYLIGHT

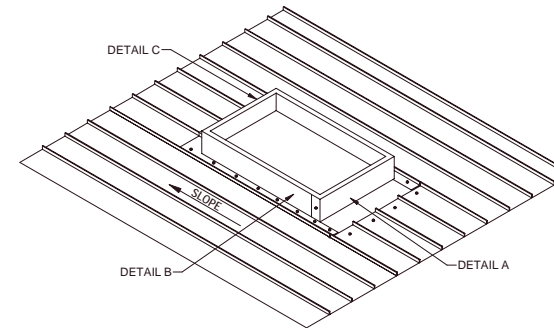

SKYLIGHT FLASHING (SIDE)

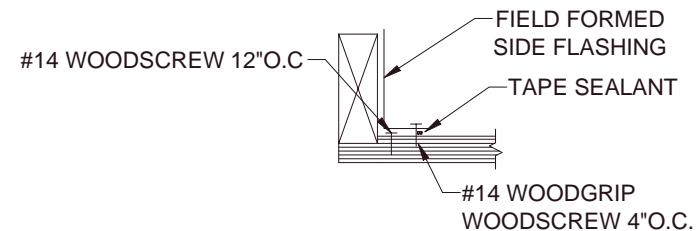

Notes:

1. In reference to details A, B, and C, refer to pages 47-48.

SKYLIGHT DETAIL "B"

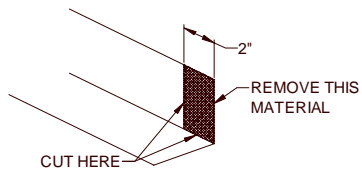
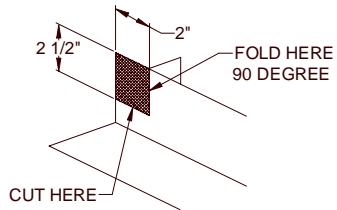
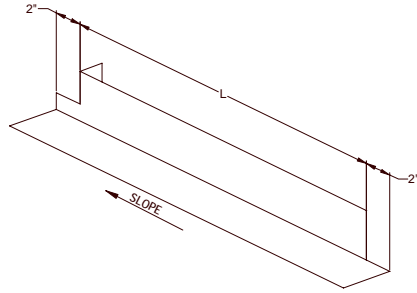

Notes:

1. Trim and bend the right side skylight flashing as indicated.
2. Trim the left side in a similar fashion. (Keep in mind the up from the down-hill ends.)

FABRAL, Inc

ESTIMATING & ORDERING A ROOF

Step 1

- A. Sketch a birds-eye view of the roof and label each section (see example below.)
- B. Sketch a diagram of each roof section.

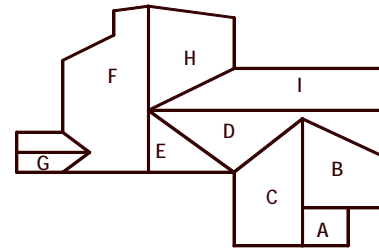

Show all measurements (see example below.) **It is important to measure exact center of the ridge to the eave edge.** Do not allow anything for overhang.

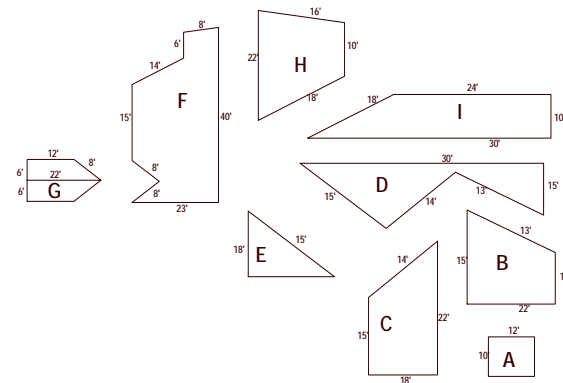

Additional Information Required: Roof Pitch, Skylights (Location & Size), Chimney (Location & Size), and Size and Number of Pipe Penetrations.

Additional Identification: Ridge, Hips, Valleys, Gables, Etc.

FABRAL, Inc

ESTIMATING & ORDERING A ROOF

Step 2

From the diagram you completed in Step 1, you are now ready to develop your roofing panel cut list. Each panel covers 24" so the only measurements you need are the distance from the eave to the ridge and the ridge length. You can then determine the number of panels needed by dividing the ridge length by the panel coverage. (See example Diagram "A" below.)

DIAGRAM "A"

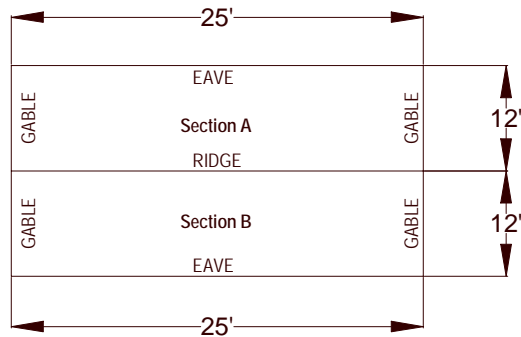

The length from the eave to the ridge is 12'. The length of the ridge is 25'; therefore, the number of panels to complete one side of the house is $25 \div 2 = 13$ pcs. Your materials list should look like Sample "B" on page 9.

FABRAL, Inc

SKYLIGHT FLASHING PREPARATION

Detail "A"

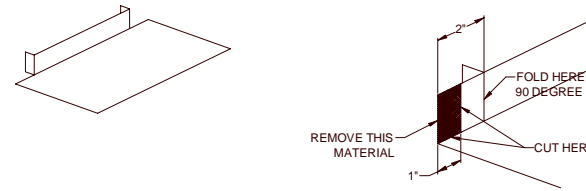

Detail "C"

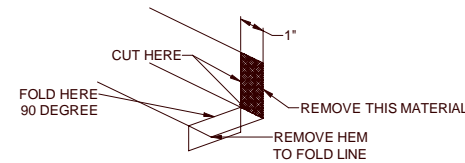

Notes:

1. Trim both ends of the uphill and downhill sides of the skylight flashing as indicated.
2. Slide the uphill flashing into the slots of the 5V Crimp roofing and apply liberal amount of sealant.
3. Assemble the skylight as indicated on pages 48-51.
4. Trim and assemble chimney flashing similarly.

FABRAL, Inc

PROCEDURE FOR THE INSTALLATION OF SKYLIGHT FLASHING

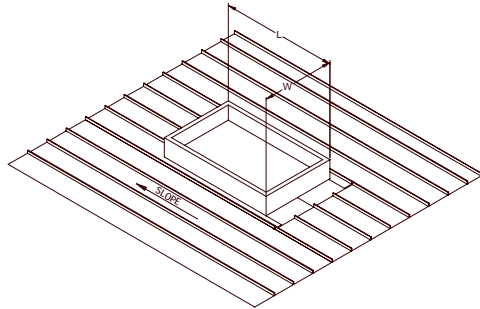

Notes:

1. Whenever possible, position the skylight curb so the ribs of the roof panels do not interfere with the flashing.
2. Cut the metal panels as close to the left, right and downhill sides of the curb as possible. Cut the uphill side 6" up from the curb as indicated above.

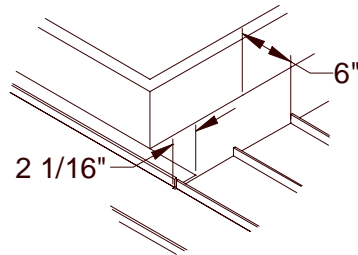

Notes:

1. The skylight flashing will be 4" wider than the width of the curb (2" on each side).
2. Cut a 1/8" slot in the two uphill corners of the 5V Crimp panels, slightly wider than 2" so the uphill flashing can slide through the two slots.

FABRAL, Inc

ESTIMATING & ORDERING A ROOF

Step 2 (Cont.)

SAMPLE "B"

Section A—13 pcs. X 12'

Now look at your roof diagram and figure out your next section of roof. Refer back to Diagram "A". Section B of this sample roof is the same as Section A. Your materials list should now look like Sample "C" below.

SAMPLE "C"

Section A—13 pcs. X 12'

Section B—13 pcs. X 12'

If your home has hips or valleys, refer to Diagram "1A" below.

DIAGRAM "1A"

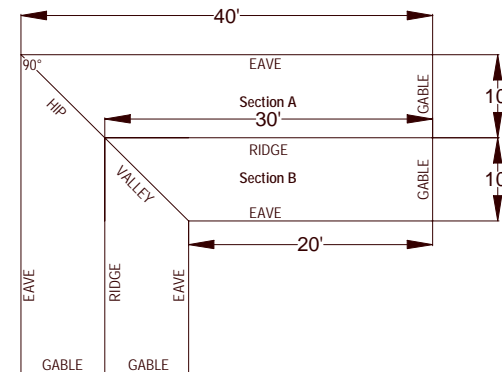

FABRAL, Inc

ESTIMATING & ORDERING A ROOF

Step 2 (Cont.)

Start with section A. The eave length is 40' and the ridge length is 30', with a difference of 10'. You will need $30 \div 2 = 15$ pcs. x 10' to reach the area where the hip starts. Remember that you have 10' remaining to cover the area, or 5 more panels. Calculate the length of each panel going into the valley by first determining the roof's pitch. Pitch is how much rise your roof has in inches for every foot of horizontal run. Use the Hip and Valley Chart below to ensure you order the correct panel length for hips and valleys. For example, Diagram "1A" is a 4/12 pitch (4/12p). According to the chart below, we know each panel will be 25 1/4" shorter. Since we are measuring from the longest point of the angle, your first piece will be the same length as the full eave to ridge measurement and each piece after will be 25 1/4" shorter. (Your list of Section A should look like Sample "D" on page 11.)

Hip & Valley Chart

When determining the panel length needed for a hip or valley, the panel will either be shorter or longer as you go up or down the hip or valley. The chart below shows you the amount to add or subtract from each panel according to the pitch of your roof. For hips and valleys where the intersecting roof planes are at 90° to one another, as in diagram 1A.

1/12p = 24"	5/12p = 26"	9/12p = 30"
2/12p = 24 5/16"	6/12p = 26 13/16"	10/12p = 31 1/4"
3/12p = 24 3/4"	7/12p = 27 3/4"	11/12p = 32 1/2"
4/12p = 25 1/4"	8/12p = 28 13/16"	12/12p = 33 15/16"

Note: When determining panel lengths, always round up to the next full inch.

FABRAL, Inc

FIELD-FORMED CRICKET OF DIVERTER -USE FOR CHIMNEYS AND LARGE OR GANGED SKYLIGHTS

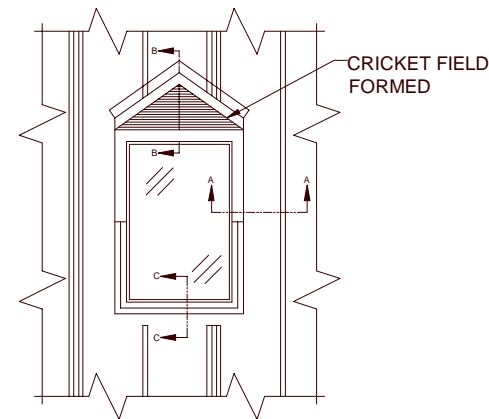
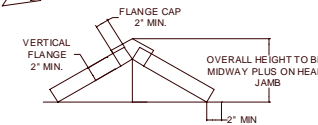
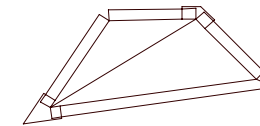
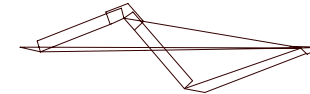
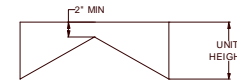
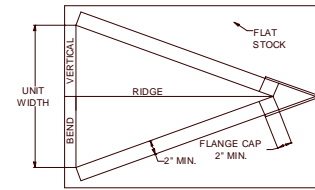

FABRAL, Inc

PIPE FLASHING

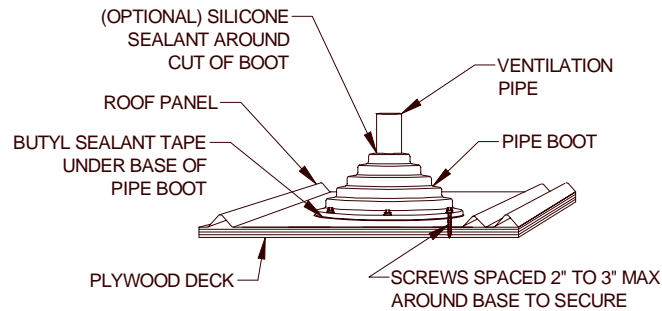

Notes:

1. Cut the hole in the flashing 20% smaller than the pipe diameter.
2. Slide the flashing down the pipe.
3. Form the flashing base to conform to the roof profile.
4. Apply sealant around the perimeter of the underside of the flashing base and fasten to the roof using #14 x 1" MP screw fasteners.

FABRAL, Inc

ESTIMATING & ORDERING A ROOF

Step 2 (Cont.)

SAMPLE "D"

Section A	16 pcs. X 10'
	1 pc. X 7'- 11"
	1 pc. X 5'- 10"
	1 pc. X 3'- 9"
	1 pc. X 2'

Refer to the Home Legend of pages 28

Step 3

and 29 for trim placement. From this diagram, you can determine the names and placement of the trim needed. All trim is produced in 10' sections only. Remember to allow 6" of overlap on all trims. Use the estimating section to determine trim quantities.

For applications of the trim flashings, see pages 30-57.

FABRAL, Inc

5V CRIMP
Estimating Guide

Accessories

Determine the total lineal feet of each condition listed below and then fill that number in on each line. Use the equations on pages 13-15 to calculate the number of pieces for each item and circle the flashing design required.

- Eave _____
- Ridge _____
- Gable _____
- Sidewall _____
- Endwall _____
- Hip _____
- Valley _____
- Transition _____
- Gambrel _____
- Skylight/Chimney width = _____

GAMBREL DETAIL

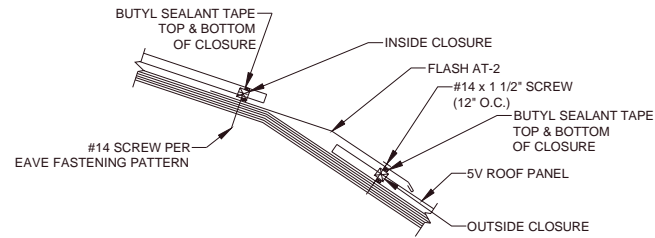

SLOPE TRANSITION (WOOD FRAMING)

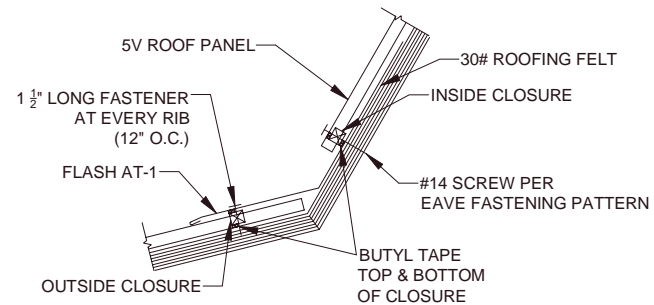

Notes:

1. **Bottom panels of the slope transition must be installed first.**
2. Mark the location of the foam closure and place a bead of butyl sealant tape on the panels. Install the closures and a second bead of sealant on top of the closures.
3. Install Slope Transition trim using #14x1½” MP screws to each main rib of the bottom transition panels.
4. Install closures, sealants, and top panels as shown above.

SWEPT WING GABLE

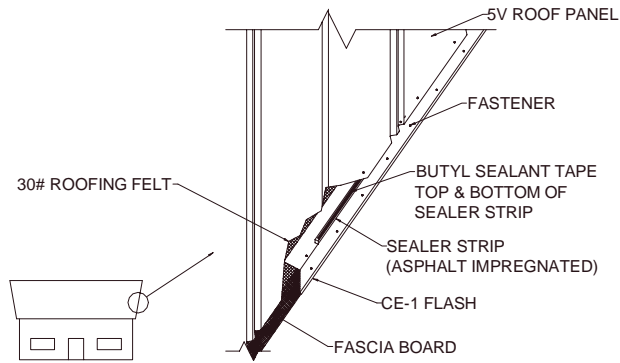

Note:

1. In high rain areas, FABRAL recommends that a high grade underlayment, such as ice and water shield, be placed 24" along the gable prior to installation of 30# roofing felt.
2. Install CE-1 Eave Trim along gable. Install 1 x 1 sealer strip with butyl sealant top and bottom.
3. Panels must be field cut to the proper angle to fit the gable.
4. Fasten the panels through the flashing and into the deck following the eave fastening pattern.

FABRAL, Inc

5V CRIMP Estimating Guide

Insert the total lineal feet of each condition into the equations below to determine required trim.

Eave: _____ ft. ÷ 10' = _____ pcs.
CE-1 EAVE

Ridge: _____ ft. ÷ 10' = _____ pcs.
RR-1 RIDGE CAP

Gable: _____ ft. ÷ 10' = _____ pcs.
WG-1 GABLE TRIM

Sidewall and Endwall:
(_____ ft. sidewall + _____ ft. end wall) ÷ 10' = _____ pcs.
ASW-1 TRIM

Hip: _____ ft. ÷ 10' = _____ pcs.
RR-1 RIDGE

Valley: _____ ft. ÷ 10' = _____ pcs.
RV-2 W-VALLEY

Slope Transition:
_____ ft. ÷ 10' = _____ pcs.
AT-1 TRANSITION
Specify both pitches ____:12 and ____:12

Gambrel: _____ ft. ÷ 10' = _____ pcs.
AT-2 GAMBREL
Specify both pitches ____:12 and ____:12

FABRAL, Inc

5V CRIMP
Estimating Guide

Fastener Calculations:

Panel Screws - Based on 18" o/c fastening
 Approximately 2 screws per lineal ft
 of panels, #14 x 1 Mill Point or
 #14 x 1½ Mill Point

Panel Lin. Ft. _____ x 2 =
 _____ #14 x 1 Mill Point
 _____ #14 x 1½ Mill Point

#14 x 1 Accessory Screws

(_____ ft. EAVE x 1/ft) + (_____ ft. GABLE
 x 2/ft) + (_____ ft. VALLEY x 3/ft) +
 (_____ ft. SKYLIGHT/CHIMNEY
 PERIMETER x 2/ft) = _____ screws

#14 x 1½ Accessory Screws

(_____ ft. RIDGE x 2/ft) + (_____ ft. SIDE
 WALL x 2/ft) + (_____ ft. ENDWALL
 x 1/ft) + (_____ ft. HIP x 3/ft) +
 (_____ ft. TRANSITION x 2/ft) +
 (_____ ft. GAMBREL x 2/ft) =
 _____ screws

SIDEWALL DETAIL

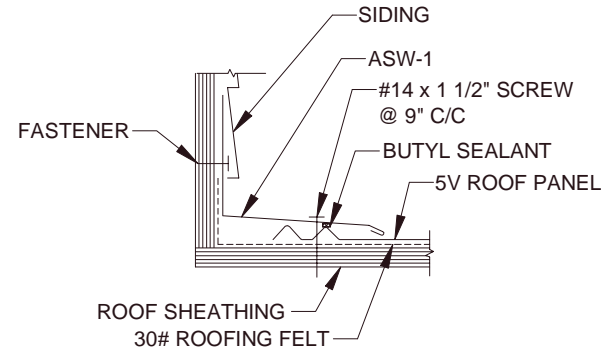

Notes:

1. The sidewall flashing is placed over the panel rib and placed behind the siding as shown.
2. When the panel rib seam does not end up next to the wall, cut the panel and bend a 1" return up the wall. (As shown below)

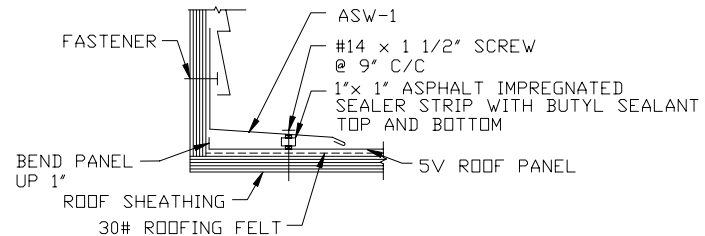

ENDWALL DETAIL

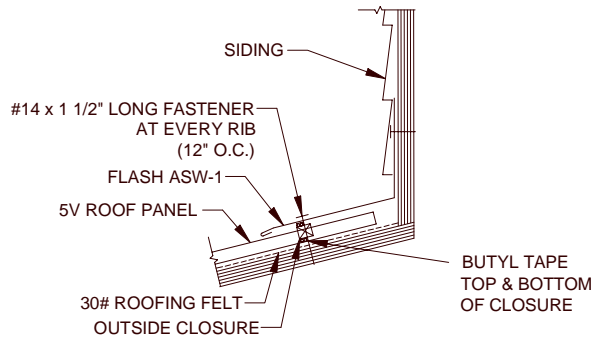

Notes:

1. Install the outside closure as shown using sealant on the top and bottom.
2. Install endwall flashing as shown.
3. When more than one endwall is needed, a 6" minimum overlap is recommended with sealant between the lap.

5V CRIMP Estimating Guide

Sealant Calculations:

1/4" x 3/16" x 40' Rolls Butyl Sealant Tape

(___ ft. EAVE x 2.06') + (___ ft. NON-

VENTED RIDGE x 4.125') + (___ ft. GABLE)

(___ ft. SIDEWALL) + (___ ft. ENDWALL x

2.06') + (___ ft. HIP x 4.5') + (___ ft.

VALLEY x 4') + (___ ft. TRANSITION x

4.125') + (___ ft. GAMBREL x 4.125') =

___ ft ÷ 40'/roll = ___ rolls

**5V CRIMP
Estimating Guide**

Closures:

1 x 1 x 19'-7" Sealer Strip

(___ ft. HIP + ___ VALLEY) ÷ 6.5

= ___ pcs.

Outside Closure

(___ ft. NONVENTED RIDGE x 1 pc./ft.)

+ (___ ft. ENDWALL x .5 pcs./ft.) +

(___ ft. TRANSITION x .5 pcs./ft.) +

(___ ft. GAMBREL x .5 pcs./ft.) +

(___ ft. SKYLIGHT/CHIMNEY x .5 pcs./ft)

= ___ pcs.

Inside Closures

(___ ft. EAVE x .5/ft.) + (___ ft. END

WALL x .5) + (___ ft. TRANSITION x .5)

+ (___ ft. GAMBREL x .5) = ___ pcs.

MONOSLOPE PEAK CAP

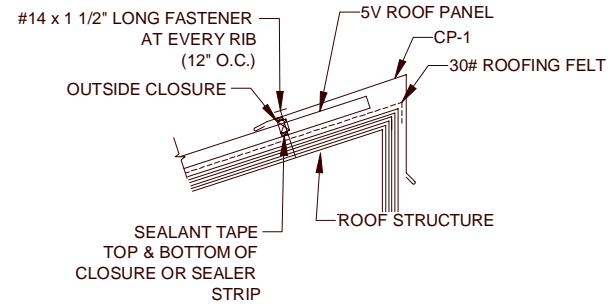

Notes:

1. Apply sealant to the bottom of the outside closure and position it on the roof panel about 1/2" up from the edge of the flashing as shown.
2. Apply sealant to the top of the closure.
3. Install flashing as shown.
4. When more than one length of flashing is used, a 6" minimum overlap is recommended. Apply sealant between the laps.

HIP DETAIL

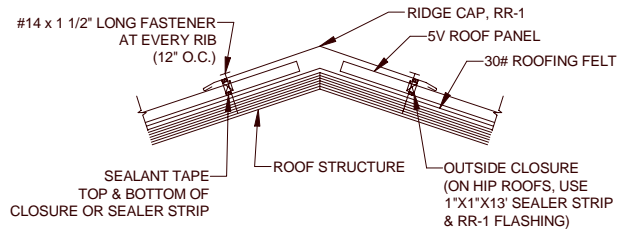

HIP ROOF—PLAN VIEW

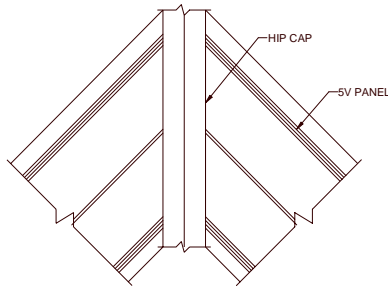

Note:

1. Hip flashing attachment is the same as for ridge flashing. (see page 39).

5V CRIMP Estimating Guide

Profile Vent for Vented Ridge:

_____ ft. of VENTED RIDGE ÷ 50 =

_____ rolls Profile Vent for 5V
(available in 100' rolls only)

Or

VersaVent RX-10 (Vent material factory applied to ridge cap)

Pipe Boots - Gray EPDM:

BASE DIAMETER	ITEM #	PIPE SIZE	
		MINIMUM	MAXIMUM
7 ³ / ₄	3	1 ¹ / ₄ "	5"
10 ³ / ₄	5	4 ¹ / ₄ "	7 ¹ / ₂ "
16 ¹ / ₂	8	7"	13"

Touch-Up Paint - 1oz. = _____

ESTIMATING & ORDERING A ROOF

Step 3 (Conf.)

When determining the number of fasteners needed, follow this GENERAL rule:

- ◆ For every linear foot of roof panel ordered, you need 2 panel screws.
- ◆ Trim screws will be calculated separately.

(Always round screws up to the nearest 100 pcs.)

Remember this is a GENERAL rule; the actual amount may vary slightly for each different roof application. At this point, your materials list for Diagram "A" should look like Sample "E".

SAMPLE "E"

Section A	13 pcs. X 12'
Section B	13 pcs. X 12'
6 pcs.	CE-1 Eave Trim 5/12p
3 pcs.	RR-1 Ridge Cap 5/12p
6 pcs.	WG-1 Gable Trim
700 pcs.	#14 x 1" MP Panel Screws
200 pcs.	#14 x 1" MP Trim Screws
100 pcs.	#14 x 1.5" Trim Screws
4 Rolls	Butyl Sealant Tape
25 pcs.	Inside Closure
1 Roll (100')	Profile Vent for 5V
	Or
	VersaVent RX-10
	1 pc.#3 Pipe Boot

You are now ready to order your new metal roof. If you have any questions, or need you materials list checked, please contact your

FABRAL, Inc

VENTED RIDGE

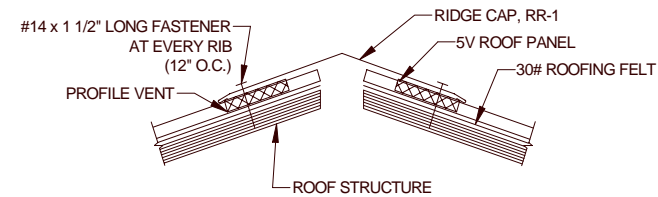

Notes:

1. Plywood should be held back or cut back 1 1/2" from each side of the ridge.
2. Attach the panels checking the 1" minimum overhang at the eave.
3. The gable flashing must be installed prior to the ridge installation.
4. Mark edge of Ridge Cap on both sides of the peak. Unroll Profile Vent and press into place about 1" upslope of mark.
5. Fasten the ridge cap using #14 x 1 1/2" MP screws on each panel rib 1" back from the edge of the Profile Vent.

FABRAL, Inc

RIDGE & GABLE DETAILS

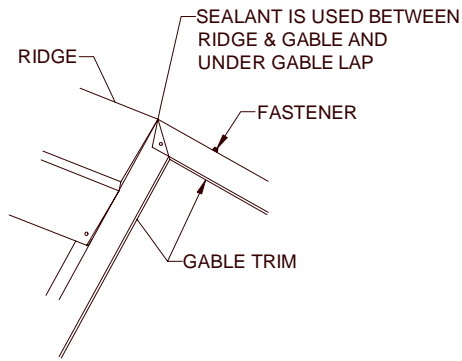

RIDGE DETAIL

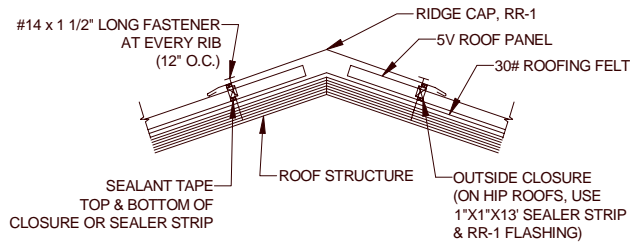

Notes:

1. Allow 1" gap between panel and center-line of ridge.
2. Mark edge of ridge cap on both sides of peak.
3. Install sealant tape about 1/2" upslope mark.
4. Position closures & press into sealant.
5. Install a second bead of sealant on top of closures.
6. Install ridge cap & fasten with #14 x 1 1/2" screws @ 12" o.c. max. as shown above.

FABRAL, Inc

5V CRIMP Order Form

Panels: Color = _____

_____ pcs. @ _____ ft. _____ in.

_____ pcs. @ _____ ft. _____ in.

_____ pcs. @ _____ ft. _____ in.

_____ pcs. @ _____ ft. _____ in.

_____ pcs. @ _____ ft. _____ in.

_____ pcs. @ _____ ft. _____ in.

_____ pcs. @ _____ ft. _____ in.

_____ pcs. @ _____ ft. _____ in.

Accessories:

_____ pcs. Of Eave Flash _____ (flashing code)

_____ pcs. Of Ridge Flash _____

_____ pcs. Of Gable Flash _____

_____ pcs. Of Sidewall Flash _____

_____ pcs. Of Endwall Flash _____

_____ pcs. Of Valley Flash _____

_____ pcs. Of Transition Flash _____

_____ pcs. Of Gambrel Flash _____

_____ pcs. Of Peak Flash _____

_____ pcs. Of J Channel _____

_____ pcs. Of #14 x 1" or 1 1/2" MP Painted Screws

_____ pcs. Of Tube Caulk

_____ pcs. Of Butyl Sealant Tape

_____ pcs. 1 x 1 x 19'7" Sealer Strip

FABRAL, Inc

NEW ROOFS

1. Make sure there are no nails or other objects protruding from the substrate that might puncture the underlayment or damage the roof panels. Clean all debris from the deck.
2. Check all details for possible roof penetrations which must be added to the deck prior to roof panel installation (vented ridge for example).
3. Cover the entire roof deck with 30-pound felt paper, Tyvar or equivalent (hereinafter referred to as underlayment). Begin at the eave at the gable end and roll out the underlayment horizontally (parallel to the eave). Allow each consecutive course to overlap the previous one at least 4". Overlap the end a minimum of 6" when starting a new roll of underlayment. Areas of underlayment that have been torn or cut should be replaced or repaired prior to installation of the metal roof. (See Illustration #1 on page 21)

FINISH GABLE DETAIL

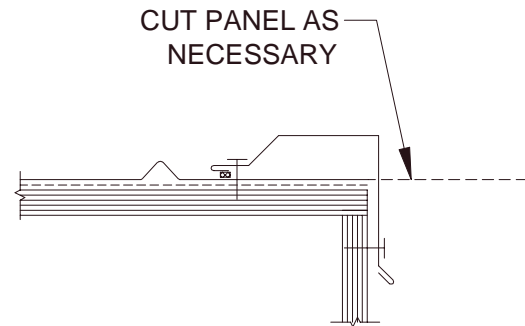

START GABLE DETAIL

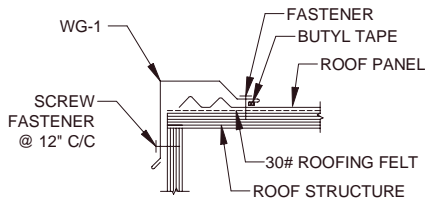

Notes:

1. Install the gable trim by positioning it into a bead of sealant over the edge of the roof as shown and fasten it to the fascia board and the roof deck at 12" on center.
2. The eave end of the gable trim can be closed off by snipping and folding.
3. For gable detail at ridge, see page 38.
4. When the last roof panel at the gable overhangs the gable edge, see the detail on page 37.

FABRAL, Inc

NEW ROOFS

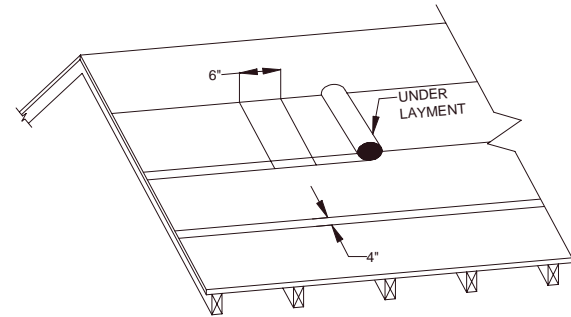
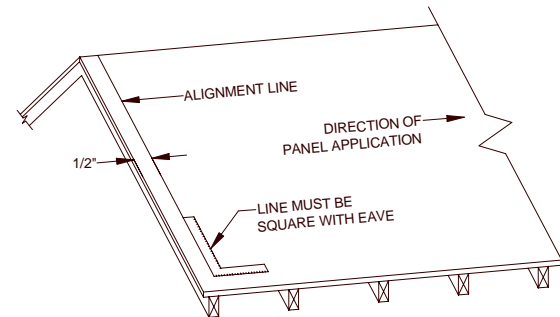

ILLUSTRATION #1

4. Place an alignment line along the gable end where the first roof panel will be installed. THIS LINE SHOULD BE 1/2" IN FROM THE GABLE EDGE OF THE ROOF DECK AND SQUARE WITH THE EAVE LINE. Various methods exist for insuring that the line is square. Call your nearest FABRAL Dealer if you need assistance. (See Illustration #2)



FABRAL, Inc

EXISTING ROOFS

In some cases, FABRAL's 5V CRIMP Panels can be installed over existing roofing.

Some jurisdictions will allow retrofit over certain types of roofing without tear-off of the old roofing. Check with your local codes or building department for the specific requirements in your area.

If the roof is to be stripped down to the existing decking, follow the procedures for new roofs on pages 20 and 21. Be sure to check the existing roof and repair any damaged areas prior to installation of the new roof system.

The following steps should be taken when installing 5V CRIMP roof panels over existing roofing.

1. Inspect the roof for damage and make any necessary repairs.
2. Secure any warped or loose roofing.
3. Make sure there are no nails or other objects protruding from the roof that might puncture the new underlayment or damage the new roof panels.
4. Remove all moss and other debris from the roof.
5. Cut off any overhanging roofing flush with the roof deck, and remove all hip and ridge caps.
6. Follow the directions on pages 20 and 21, #2 through #4, on roof preparation.

Note: For best results, 5V CRIMP requires a relatively smooth and flat substrate. Application over rough and/or uneven surfaces is not recommended.

FABRAL, Inc

VALLEY DETAIL

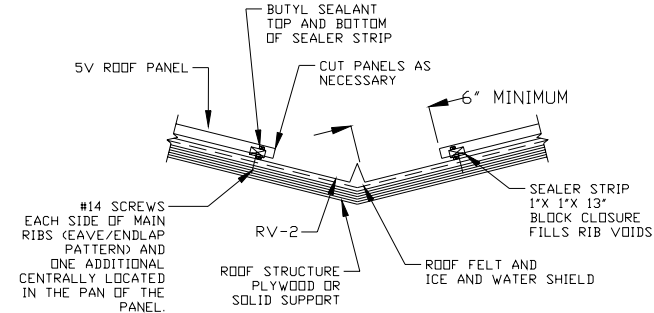

Notes:

1. Not all layers of roofing underlayment are shown.
2. Adhere ice & water shield to decking at valley location and install a layer of 30# felt.
3. Place a second layer of 36" roofing underlayment in the center line of the valley with 18" of underlayment on each side of the valley.
4. When valley flashing is overlapped, a minimum of 6" of lap is recommended with sealant applied between the pieces of valley trim at the endlap.
5. Install Butyl Sealant Tape and 1x1x13' Sealer Strip parallel to the valley flashing as shown above.
6. Field cut the roofing panels holding back 4" from valley as shown.
7. Fasten the panels to the valley flashing as shown 6" on center using the proper fastener (see page 24).

FABRAL, Inc

EAVE DETAIL

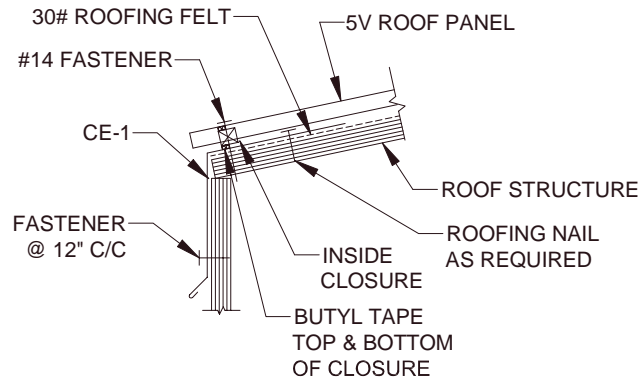

Notes:

1. Tack the eave flashing in place under the underlayment using a few roofing nails. Fasten the eave trim to the fascia with a painted screw fastener @ 12" o.c.
2. Panels should overhang the eave 1".

PANEL INSTALLATION

Note: Prior to panel installation, determine which items need to be installed prior to panels (such as eave, valley, swept wing, etc.)

1. Working off the eave edge, establish a straight line up the gable edge from which you are starting. This will insure that the first panel laid will be straight and square with the eave. (See Illustration #2)
2. Before fastening the panel to the roof deck, install the eave trim and tack in place with roofing nails.
3. Once the first panel is in proper position, secure it to the roof deck #14 x 1" mill point screws, according to the standard fastening pattern.
4. Install the gable trim and face screw it to fascia board (see page 38). This fully secures the first panel to the roof deck.
5. Position the second panel (overlap edge on top of the underlap edge of first panel) assuring that the eave edge is in position (1" overhang). Secure the second panel to the deck. Fasten the panel to the roof deck by installing fasteners as in step #3 above.
6. Each consecutive panel will be installed as in step #3 and #5 above.
7. In high wind areas, it is recommended that the panels be fastened at the eave using the standard eave fastening pattern.

5V CRIMP TRIM PARTS
See page 28-33 for
Illustration of Trim Conditions

Key Terms

RIDGE CAP

This piece is used at the peak of a two-slope roof. The ridge can be ventilated by using profile vent in place of outside closures & sealant.

HIP CAP

This piece covers projecting angles formed at the intersection of the two sloping roof planes.

GABLE TRIM

This piece is installed on the edge of the roof between the ridge and the eave, holding down the first panel edge and the last panel edge.

EAVE TRIM

This piece is used at the eave or gutter edge of the building, and must be installed before any panels.

W-VALLEY

Used to flash the valley formed by intersecting roof planes.

SIDEWALL

This piece is used when the roofing panel is installed parallel to a vertical wall.

ENDWALL

This piece is used when the upper end of panel butts into a vertical wall.

**5V CRIMP
TRIM ENLARGEMENTS**

TRANSITION AT-1

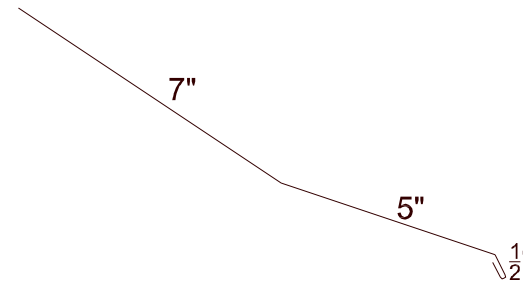

GAMBREL AT-2

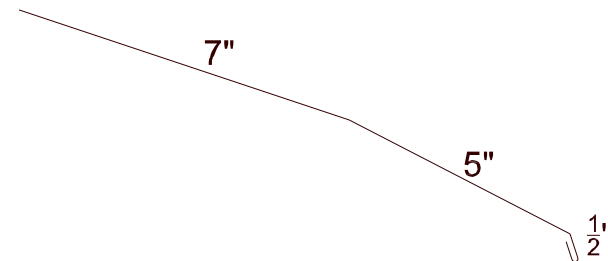

**5V CRIMP
TRIM ENLARGEMENTS**

RIDGE/HIP RR-1

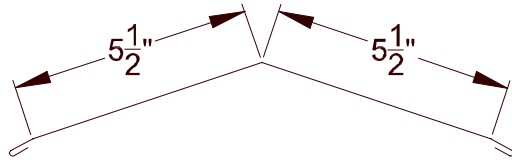

**SIDEWALL/ENDWALL
ASW-1**

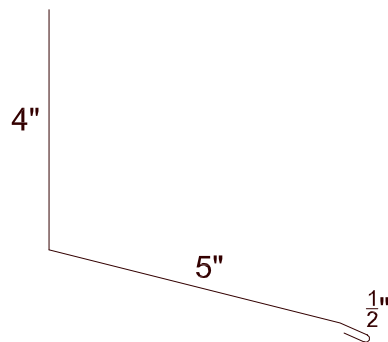

FABRAL, Inc

5V CRIMP TRIM PARTS
See page 28-33 for
Illustration of Trim Conditions

Key Terms

MONOSLOPE PEAK CAP

This piece is used at the top of a single-sloped roof.

SLOPE TRANSITION

This piece is used where two roofs of different pitch meet; the top section being steeper than the lower section.

GAMBREL CONDITION

This trim is used to transition from a low slope to a steep slope.

CHIMNEY OR SKYLIGHT

See pages 47 ~ 55.

FASTENERS



#14 x 1" or #14 x 1 1/2" Mill Point Screw

This fastener is used to attach panels and trim.

This list of flashing can be used in conjunction with the Home Legend drawing on pages 26 and 27 to help you understand placement and proper installation.

FABRAL, Inc

**5V CRIMP
FASTENERS**

# Fasteners	Description	Use
Approx. 2 Per foot Of Panel Plus Trim	 #14 x 1" Mill Point Screw	Panels and Trim
Approx. 2 per foot Of panel Plus Trim	 #14 x 1 1/2" Mill Point Screw	Panels and Trim

◆ Note: either 1" or 1 1/2" screws can be used to fasten panels.

Listed above are the fasteners recommended for the proper installation of the 5V CRIMP panels. Also note the diagram below for proper installation of gasketed fasteners.

PROPER INSTALLATION OF GASKETED FASTENERS



correctly
driven

under
driven

over
driven

FABRAL, Inc

**5V CRIMP
TRIM ENLARGEMENTS**

GABLE WG-1

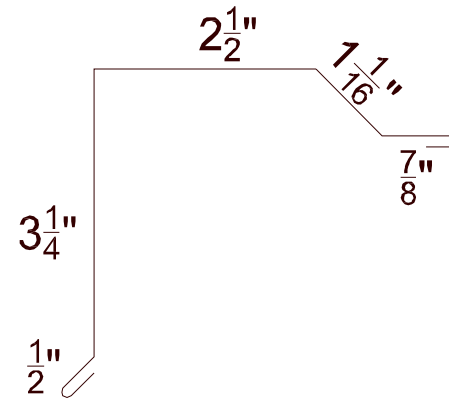

VALLEY RV-2



FABRAL, Inc

5V CRIMP
TRIM ENLARGEMENTS

EAVE CE-1

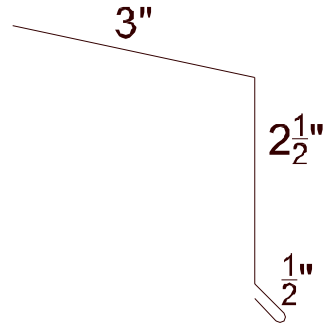

MONOSLOPE PEAK CAP CP-1

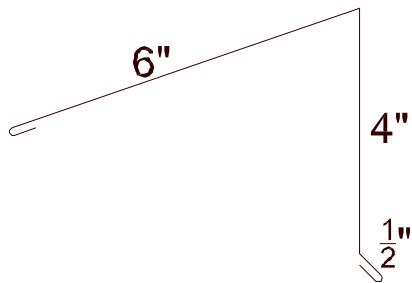

FABRAL, Inc

26 GA. 5V CRIMP SELF HELP KIT

Wind Load Tables—Steel Panels

ALLOWABLE WIND UPLIFT LOAD (PSF)

Decking	12"	15"	18"	21"	24"
7/16" OSB	34.60	27.68	23.07	19.77	17.30
19/32" OSB	56.60	45.28	37.73	32.34	28.30
23/32" OSB	65.20	52.16	43.47	37.26	32.60
1/2" Plywood	76.40	61.12	50.93	43.66	38.20
5/8" Plywood	90.00	72.00	60.00	51.43	45.00
3/4" Plywood	155.0	124.0	103.3	88.57	77.50

5V

Crimp Fastening Schedule

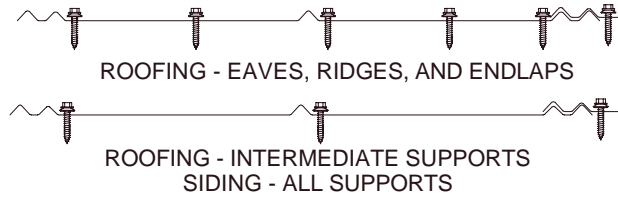

FABRAL, Inc

**5V CRIMP
INSTALLATION GUIDE**

**5V CRIMP - INSTALLATION GUIDE
Enlargements of trims shown on pages 30-33**

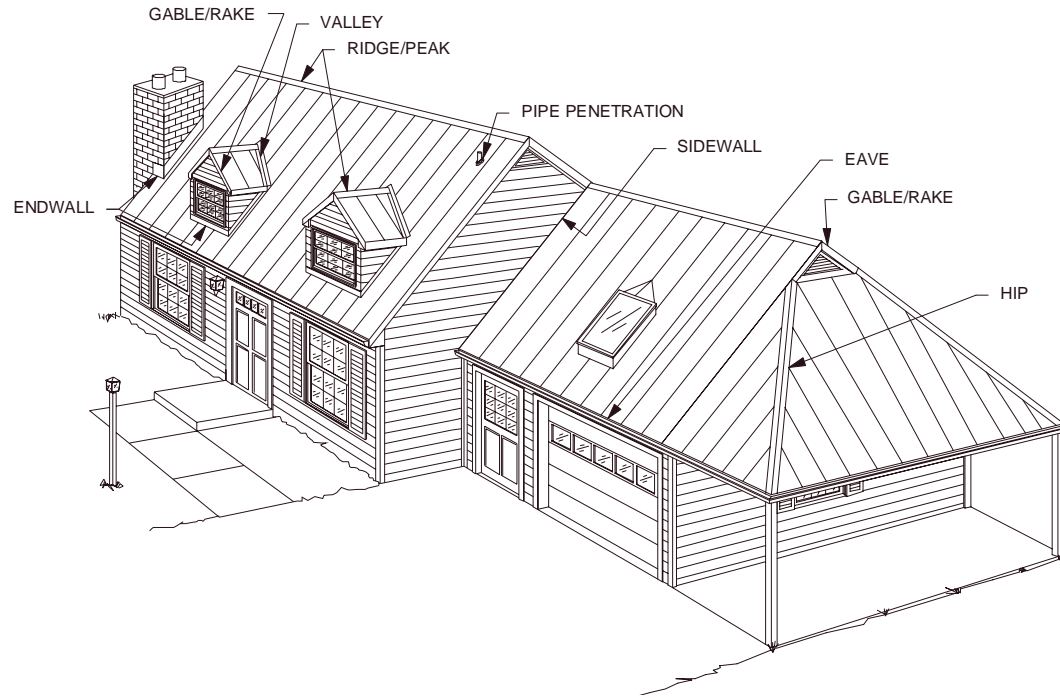

EAVE CE-1

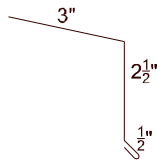

MONOSLOPE PEAK CAP CP-1

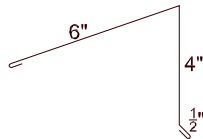

RIDGE/HIP RR-1

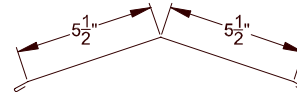

SIDEWALL/ENDWALL ASW-1

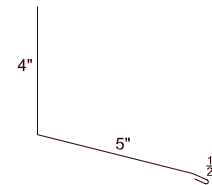

GABLE WG-1

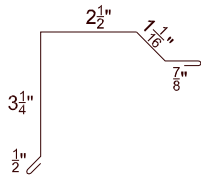

VALLEY RV-2

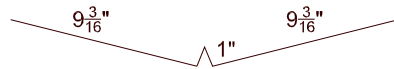

TRANSITION AT-1

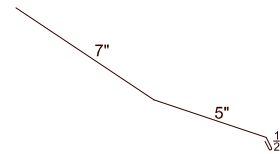

GAMBREL AT-2

